

BROAD
Combats
POLLUTION



BROAD CLEAN AIR 400-677-6666

AIRPRO HOME

BROAD Clean Air Product AirPro Collection

Filter PM2.5 by 99%

AirPro Home:
Protecting your family's health

Model : FD2



Standard: GB/T18801-2015

BROAD CLEAN AIR TECHNOLOGY
远大洁净空气科技有限公司

Sales: 400-677-6666 www.broadair.net

Service: 400-883-9333 BROAD Town, Changsha, China

Air Volume 200 m³/hr

Area Coverage 10~20 m²

Filter PM2.5 by 99%

HEPA filter to be replaced:
every 3,000 hrs



■ Structural Diagram

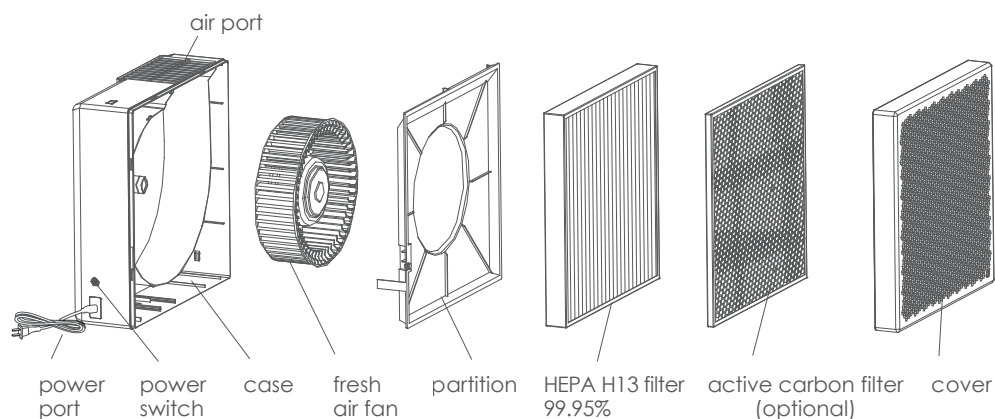

■ Troubleshooting

No.	Problem	Cause	Solution
1	Insufficient air volume	The HEPA filter is blocked	Replace the HEPA filter
2	The outlet grille is stained	The polluted air flows back (if the filter is faulty, there is likely dirt in the fan)	Clean with a towel (to prevent water from entering the fan)
3	Button failure	The button is stuck or the wire is broken	Repair or replace it
4	The fan doesn't work	The power plug is loose and has poor contact	Unplug and plug back in
		The fan or the circuit board is broken	Repair or replace it

■ Parameter Table

Item	Level 1	Level 2	Level 3	Level 4	Level 5	Level 6
Air Volume m ³ /h	60	80	110	140	160	200
Power W	5	6	8	12	15	20
Noise dB(A)	25	30	36	40	42	46
Battery	AC 100~220V					
Filtration Efficiency	Filter PM2.5 by 99%					

■ Air Volume Adjustment

Press the power switch to switch levels:

- Level 1 & 2 (blue light)
- Level 3 & 4 (green light)
- Level 5 & 6 (yellow light) : High air volume (Note the AirPro will be more audible at this setting)

■ Warranty

- 1-year warranty from the date of purchase. For problems caused by design, manufacturing or transportation from factory, free repair or replacement will be provided
- If the user is unable to provide a valid proof of purchase, the warranty period should be extended by 3 months according to the production date shown on the unit
- If the AirPro was damaged due to inappropriate use or storage, or the sticker was torn off, there will be a charge for repair

■ Filter Replacement

(operate after shutdown and power off)

- When the air volume is less than 70%, the HEPA filter needs to be replaced
- Replace the HEPA filter: Open the cover, take out and replace the HEPA filter. The HEPA filter should be replaced after 3,000 hours of use. When installing the HEPA filter, the arrow direction should be inward
- Activated carbon is useful for absorbing toxic chemical fumes or gas, but it is very thin and easy to saturate. It should be replaced after 100 ~ 200 hours of use. For newly renovated room, replace it every week

■ Maintenance

- Replace the HEPA filter when needed
- Keep the AirPro away from liquid
- Avoid hitting, dropping or impacting the AirPro
- Design life: 20 years (the bearing may need to be replaced during this period)

Quality Certificate/ Warranty Card

Name: AirPro Home

Model: FD2

Serial Number:

Inspector:

Date of Purchase:

Shop:

Seller:

